

# Technical Bulletin

Bulletin Number: 399 Revision Number: R-02

Release Date: January 22, 1990 Revision Date: April 14, 1993

**SUBJECT: SERIES 90 VENDER PARTS**

**MODELS:** All DNCB Series 90 Venders.

- REASON:**
1. To provide a description and part number for the Series 90 vend motors, vend motor cams, vend/by pass switch, sold out switches and sold out paddles.
  2. To remove the Cam Hold Switches from the Circuits and still maintain the same level of Electrical Reliability and Performance.

**BEGINNING**

- SERIAL NUMBERS:**
- A. Run Number 3161AO\*\* (100 Venders Manufactured).
  - B. 0001-3162AO and all models thereafter except Run Number 3164AO, 3166DN and 3167AO.
  - C. Vend Motors are not interchangeable with vend motors on venders manufactured prior to the Series 90 beginning Serial Number.

- COUNTER SOCKET:**  
**CHANGER SOCKET:**  
**RELAY SOCKET :**  
**SEQUENCER :**
1. Are mounted in the control panel.

**VEND MOTORS:** Two motors are used on DNCB 1 1/4" Venders - 1 for narrow column and 1 for wide column.  
Two motors are used on T Models, DNCB 489 and DNCB 588 Venders - 1 for narrow column and 1 for wide column.  
Motors and Sold Out Switches are located under the vend motor cover.

\*\*The 100 Series 90 Coke venders on production run 3161AO are serialized as:  
1954-3161AO to 2003-3161AO and 2656-3161AO to 2705-3161AO

**CAMS FOR VEND MOTORS**

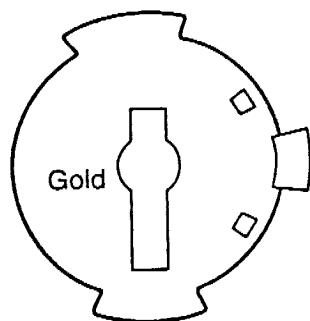

**1. Adjustable Cam:**

**A: Where Used:**

1. DNCB adaptable & dual adaptable wide column
2. DNCB T-Models and DNCB 489 and 588 single, double or triple depth wide columns

**B: Color: Gold**

**C: Part No.: 801,806,400.11**

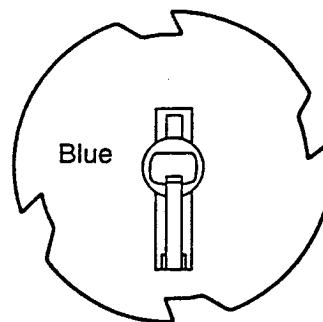

**2. Vending Cam:**

**A: Where Used:**

1. DNCB adaptable and dual adaptable single and double depth wide column
2. DNCB T-Models and DNCB 489 and 588 single depth wide column

**B: Color: Blue**

**C: Part No.: 801,806,390.11**

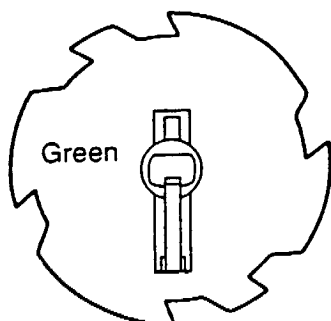

**3. Vending Cam**

**A. Where Used:**

1. DNCB T-Models and DNCB 489 and 588 double or triple depth wide columns

**B. Color: Green**

**C. Part No.:**  
801,806,410.01

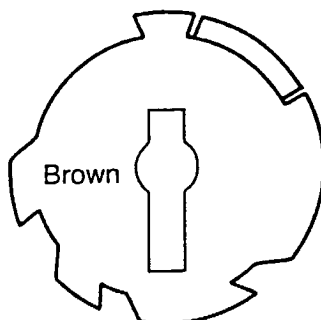

**4. Adjustable Cam**

**A: Where Used:**

1. DNCB adaptable & dual adaptable narrow columns
2. DNCB T-Models and DNCB 489 and 588 single, double or triple depth narrow columns

**B. Color: Brown**

**C. Part No.:**  
801,806,610.21

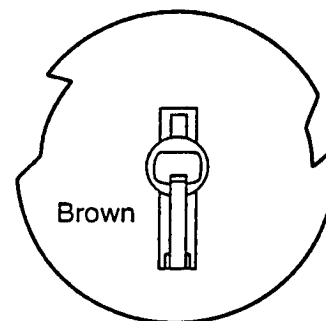

**5. Vending Cam**

**A: Where Used:**

1. DNCB adaptable and dual adaptable narrow column
2. DNCB T-Models and DNCB 489 and 588 single, double or triple depth narrow column

**B. Color: Brown**

**C. Part No.:**  
801,806,180.21

## CAM INSTALLATION AND REMOVAL

**CAUTION:** Depress the switch actuators when installing the vending and adjustable cams to prevent possible damage to the actuators.

### TO INSTALL A VENDING CAM:

1. Select the vending cam required. (See page 2).
2. Locate the hub at the center of the cam. (See Fig. 5).
3. With the hub facing you, align the shaped hole in the cam with the vend motor shaft, slowly slide the cam onto the shaft while depressing the lock tab. (See Fig. 6).  
NOTE: Reference timing section below for instruction on setting the timing of the motors and cams.
4. A click will be heard when the tab has locked into the locator hole of the motor shaft.

### TO INSTALL AN ADJUSTABLE CAM:

1. Select the adjustable cam required. (See page 2).
2. Locate the tab on the outer edge of the cam. (See fig. 6).
3. With the tab facing you, align the slot of the adjustable cam with the lock tab of the vending cam.
4. Place the adjustable cam onto the vending cam and rotate the adjustable cam until it locks in place.
5. To adjust to a different setting, lift the tab of the adjustable cam and rotate the adjustable cam clockwise until the desired setting is reached.

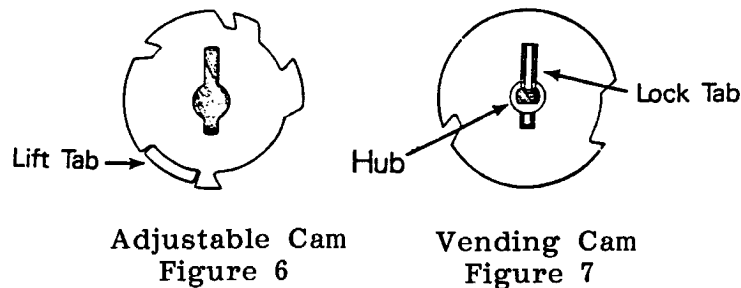

### TO REMOVE AN ADJUSTABLE CAM:

1. Lift the tab and rotate the adjustable cam clockwise until the vending cam lock tab is aligned with the slot of the adjustable cam.
2. Remove the adjustable cam from the hub of the vending cam.

### TO REMOVE THE VENDING CAM:

1. Depress (push in) the lock tab firmly to disengage it from the motor shaft.
2. At the same time, pull the vending cam towards you until it is removed from the motor shaft.

## TIMING

### TO SET THE TIMING OF A NARROW COLUMN VEND MOTOR:

1. Make sure the hole through the rear shaft of the vend motor is in a horizontal plane. (If a pin were inserted in the hole, the pin would be horizontal.) See Fig. 8.
2. The vend rotor must be in the loading position when the motor shaft is inserted into the end of the rotor. See Fig. 8.
3. Insert the motor shaft into the rotor and secure the motor.
4. Install the vending cam onto the front shaft of the motor making sure the lock tab is at the 9 o'clock position. See Fig 7.
5. Install the adjustable cam per the instructions on page 3.

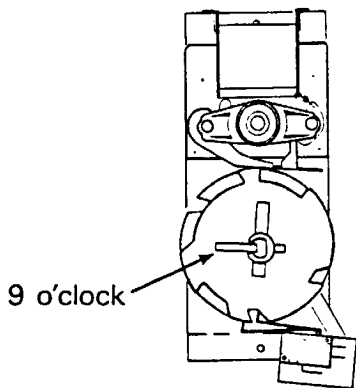

Figure 7

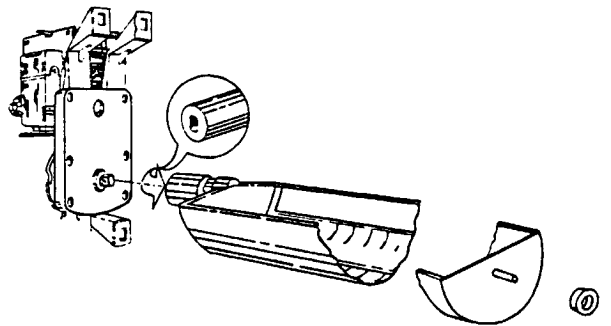

Figure 8

**TO SET THE TIMING OF A WIDE COLUMN VEND MOTOR.**

1. Make sure the hole through the rear shaft of the motor is in a horizontal plane. (If a pin were inserted in the hole, the pin would be horizontal). See figure 10.
2. Slide the Drive Arm (with linkage attached) onto the rear shaft as shown. See figure 10.
3. Secure by installing the groove pin.
4. With the oscillator in position, align the hole in the linkage arm with the shaft of the oscillator.
5. Slide the linkage onto the shaft and secure the motor.
6. Install the vending cam onto the front shaft of the motor making sure that the lock tab is at 6 o'clock as shown. See figure 11.

**NOTE:** When the screw holding the linkage arm to the drive arm is at 12 o'clock position (See Fig. 10), the lock tab will be at the 6 o'clock position (See Fig 11).

7. Install the adjustable cam per the instructions on page 3.

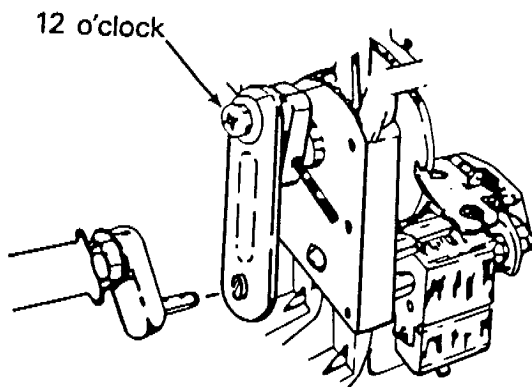

Figure 10

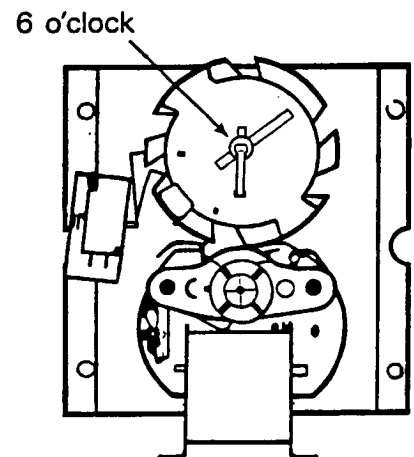

Figure 11

## SOLD OUT SWITCHES (2 per cluster)

The Sold Out Switches are located on the front mechanism plate near the bottom of each column. The Vend Motor Cover must be removed to access the switches.

The Sold Out Switches are the "snap-in" type. To install, place the switch over the opening. In the front mechanism plate, push in and at the same time, slide to the right.

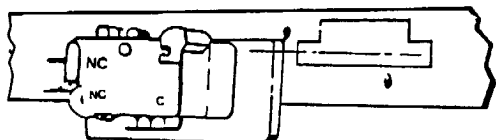
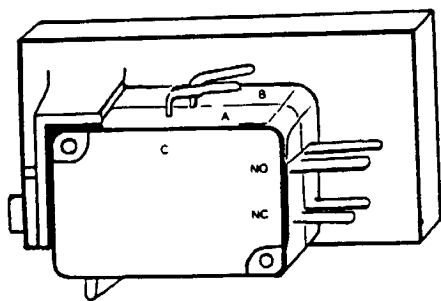
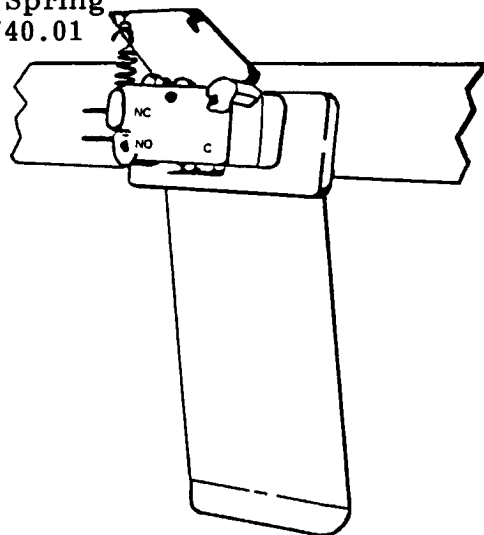

Figure 12



Sold out Switch Assy  
804,100,610.01

Sold out Spring  
901,700,740.01



Sold out Paddle  
432,070,170.03

### (A) Front sold Out Switch (one per column)

The N.C. contact of the front sold out switch is in the Vend Relay Coin Circuit and the Coin Changer Inhibit Circuit. The N.C. contact is in parallel with all the other N.C. contacts of the Front Sold Out Switches and when all are open, the coin changer will not accept coins.

The N.O. contact of the front sold out switch has no function.

### (B) Vend sold Out Switch (one per vending circuit)

The N.C. Contact of the Vend Sold Out switch is in the Vend Motor Circuit. When product is present in a column, the N.C. contact stays closed in the vend motor circuit so the Vend Motor Circuit can be completed.

The N.O. contact of the Vend Sold Out Switch is in the Sold Out Lamp circuit. When not kept open, the N.O. contact closes and completes the Sold Out Lamp circuit.

## REAR SPACER

The rear spacer, one for each column, is located vertically at the rear of the column. The latch fingers slide into the holes in the column walls to secure the spacer. The rear spacer is adjusted depending on the package to be vended. (See appropriate technical bulletin or contact the Dixie-Narco Factory Service Department for the proper setting).

Figure 13 - The latch fingers are in the open position with the lock tabs disengaged.

Figure 14 - The latch fingers are in the closed position with the lock tabs engaged. Make sure the tabs are in a locked position as shown, before loading the vender.

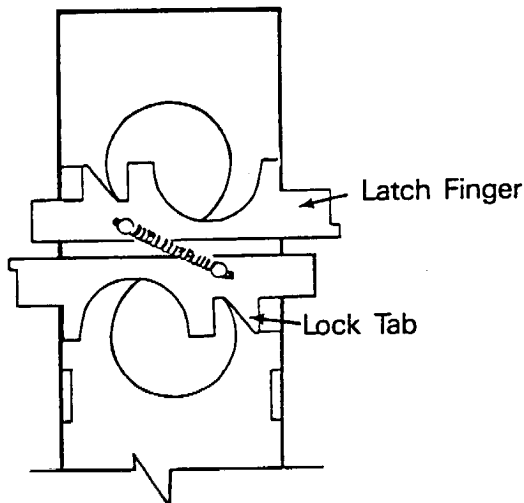

Figure 14

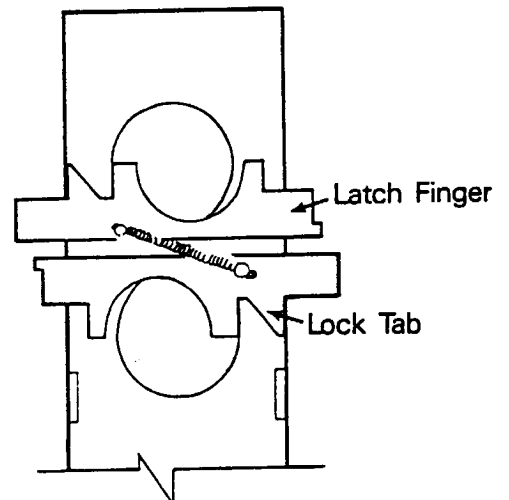
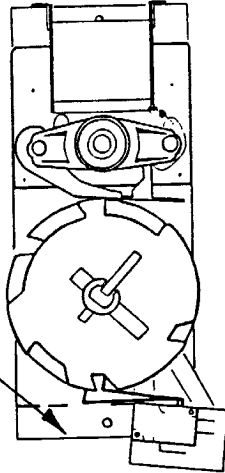
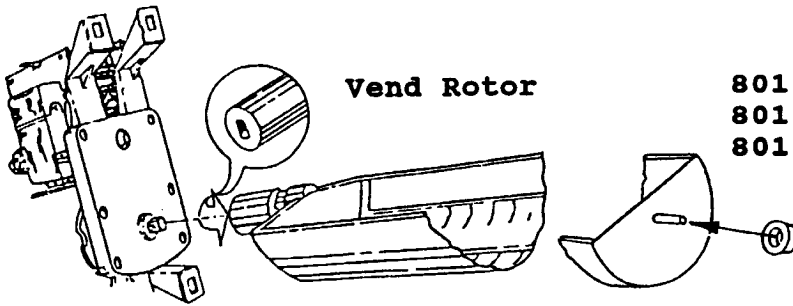

Figure 13



**Vend Motor Switch**  
804,100,690.01

**Vend Motor - Narrow Column**  
491,070,400.03 - 1-1/4"  
497,070,900.03 - T Models



**Vend Rotor**

801,201,211.61 - 1-1/4"  
801,201,230.01 - 489/588  
801,201,220.01 - T Models

**Nyliner**  
801,803,170.01

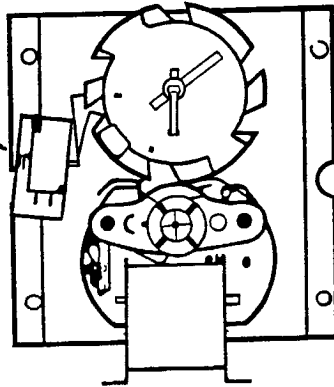

**Vend Motor Switch**  
804,100,690.01

**Vend Motor - Wide Column**  
491,070,300.03 - 1-1/4"  
497,070,800.03 - T Models

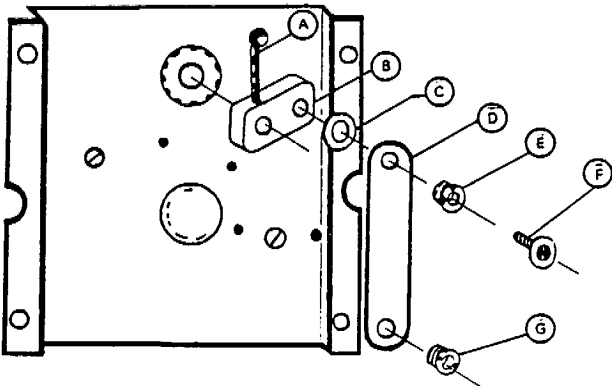

A.	Groove Pin	900,901,940.01
B.	Drive Arm	801,200,950.51
C.	Washer	900,700,600.01
D.	Linkage Arm	A801,201,030.01
E.	Nyliner Bearing	801,803,160.01
F.	Sems Screw	900,301,640.01
G.	Nyliner	801,804,770.01



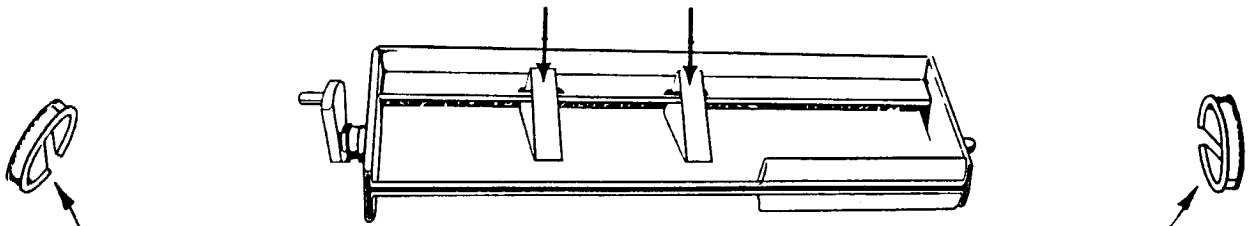

Oscillator Assembly  
491,070,900.03 - 1-1/4"  
497,071,000.03 - T Models

Nyliner (Rear Spacer)  
801,803,170.21

Nyliner (Front Spacer)  
901,804,230.01

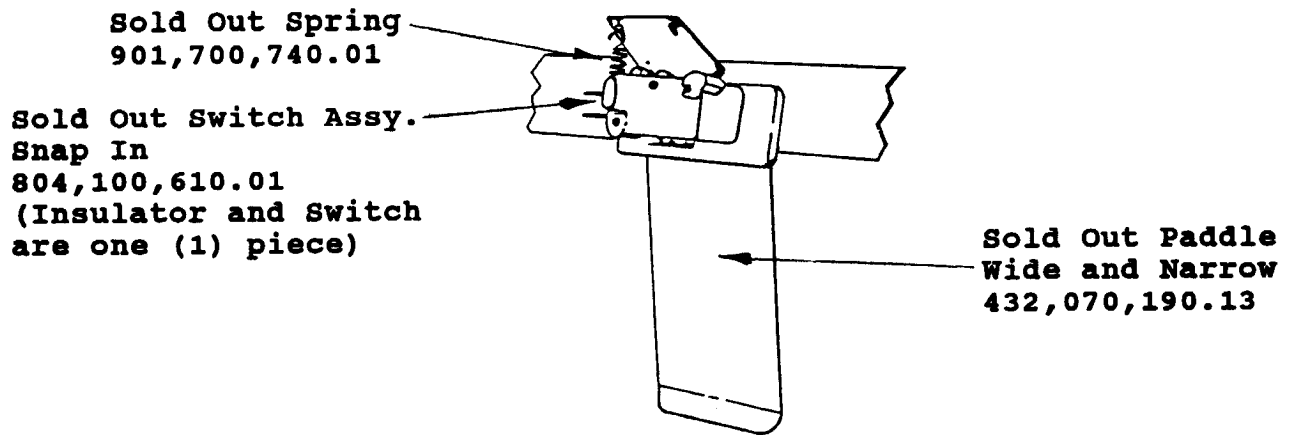

Sold Out Spring  
901,700,740.01

Sold Out Switch Assy.  
Snap In  
804,100,610.01  
(Insulator and Switch  
are one (1) piece)

Sold Out Paddle  
Wide and Narrow  
432,070,190.13

## WIRING - SERIES 90

### DOOR WIRING HARNESSES - SERIES 90

<u>Description</u>	<u>Old # (Obsolete)</u>	<u>New #</u>
8 Select Flat (Apple Black, Everfresh, etc.)	C269,050,201.13	804,902,551.01
6 Select Flat	C273,050,101.23	804,903,800.11
5 Select Flat	C283,050,100.93	804,902,570.61
10 Select Flat	C350,050,200.83	804,902,560.91
8 Select Magnum	C360,050,400.83	804,903,690.11
10 Select Magnum	C365,050,400.73	804,903,700.11
6 Select Magnum	C369,050,400.53	804,903,710.11
5 Select Magnum	C419,050,100.53	804,903,720.11
7 Select CC	C432,050,100.23	804,902,320.71
9 Select CC	C437,050,100.23	804,902,470.31
6 Select CC	C443,050,100.23	804,902,480.51
5 Select CC 180	C445,050,100.23	804,902,490.71
5 Select CC 300	C448,050,100.33	804,902,500.31
8 Select D3/B7	C453,050,600.23	804,903,780.11
6 Select D3/B7	C456,050,400.23	804,902,510.31
5 Select D3/B7	C459,050,400.23	804,904,410.01
10 Select D3/B7	C461,050,300.23	804,903,790.11
8 Select RND. GNRC	C469,050,300.33	804,902,551.01
10 Select RND. GNRC	C471,050,100.33	804,902,560.91
6 Select RND. GNRC	C477,050,200.33	804,903,800.11
8 Select CC	C444,050,100.23	804,902,330.41

### Cabinet Wiring Harnesses Series 90

<u>Description</u>	<u>Old # (Obsolete)</u>	<u>New #</u>
5 Select	F172,072,500.53	804,902,420.81
6 Select	F176,073,201.33	804,902,410.91
7 Dual Select	F231,071,101.13	804,902,350.81
8 Dual Select	F241,070,101.33	804,902,360.61
6 Dual Select	F251,070,100.83	804,902,430.71
10 Select	F350,070,500.83	804,902,380.71
9 Select	F356,070,100.53	804,902,370.41
7 Dual T Select	F361,070,300.43	804,902,390.71
8 Dual T Select	F386,070,300.43	804,902,400.91

### Vend Motor Covers Series 90

All 28" Wide Venders - 493,170,010.33  
All 36" Wide Venders - 491,070,050.33

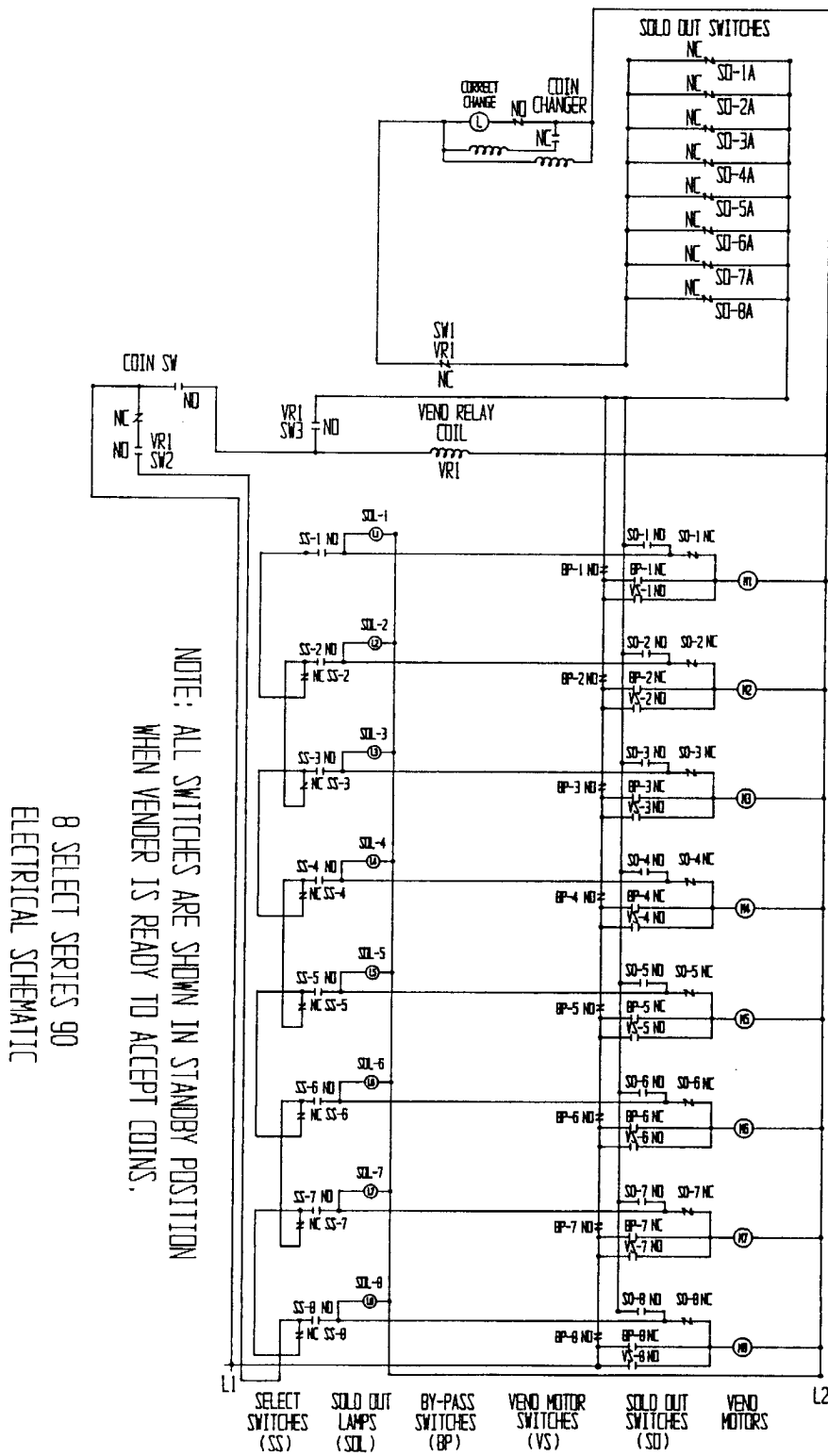

NOTE: ALL SWITCHES ARE SHOWN IN STANDBY POSITION  
WHEN VENDOR IS READY TO ACCEPT COINS.

9 SELECT SERIES 90  
ELECTRICAL SCHEMATIC

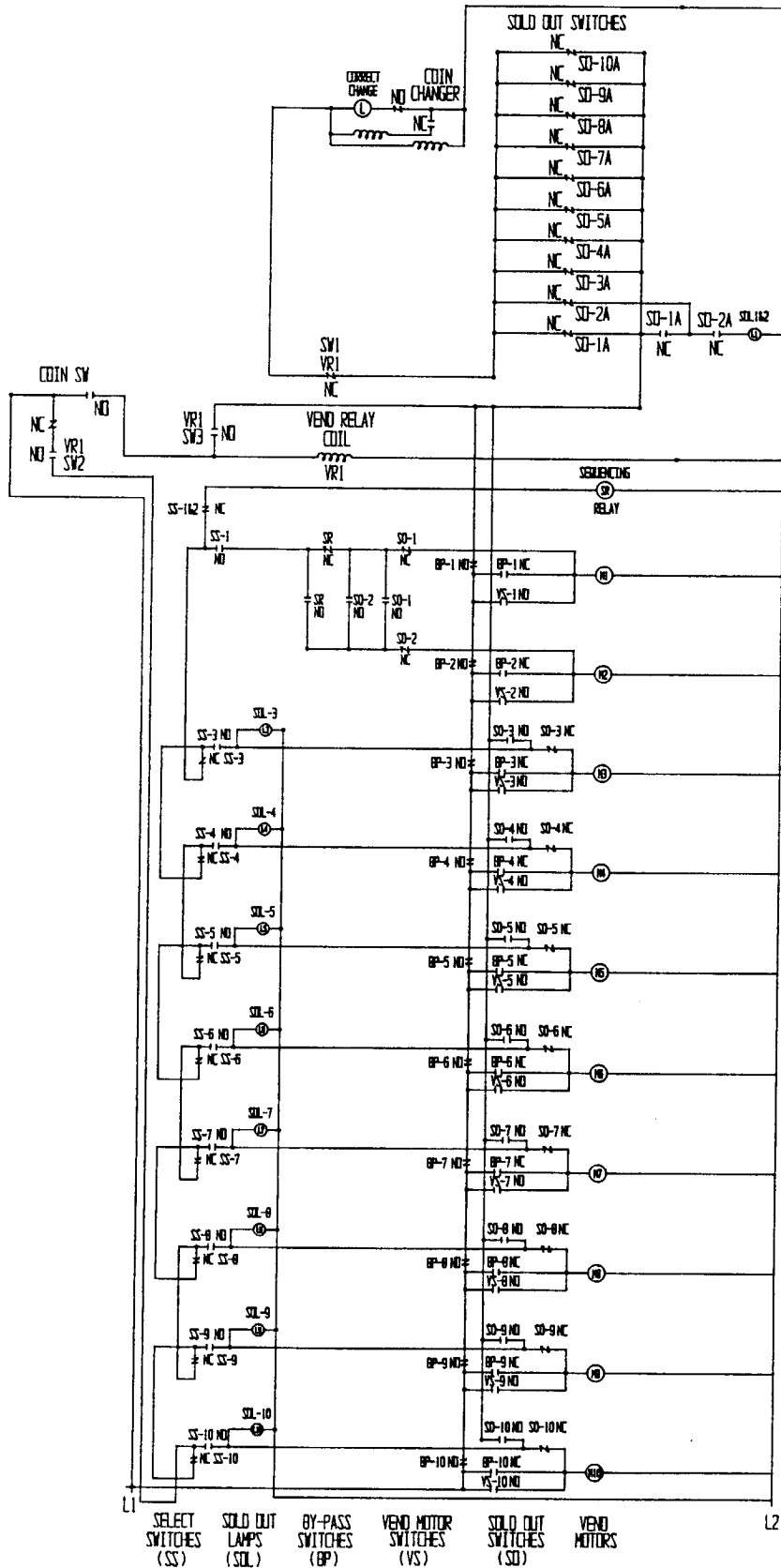

NOTE: ALL SWITCHES ARE SHOWN IN STANDBY POSITION  
WHEN VENDOR IS READY TO ACCEPT COINS.

10 SELECT SERIES 90  
ELECTRICAL SCHEMATIC

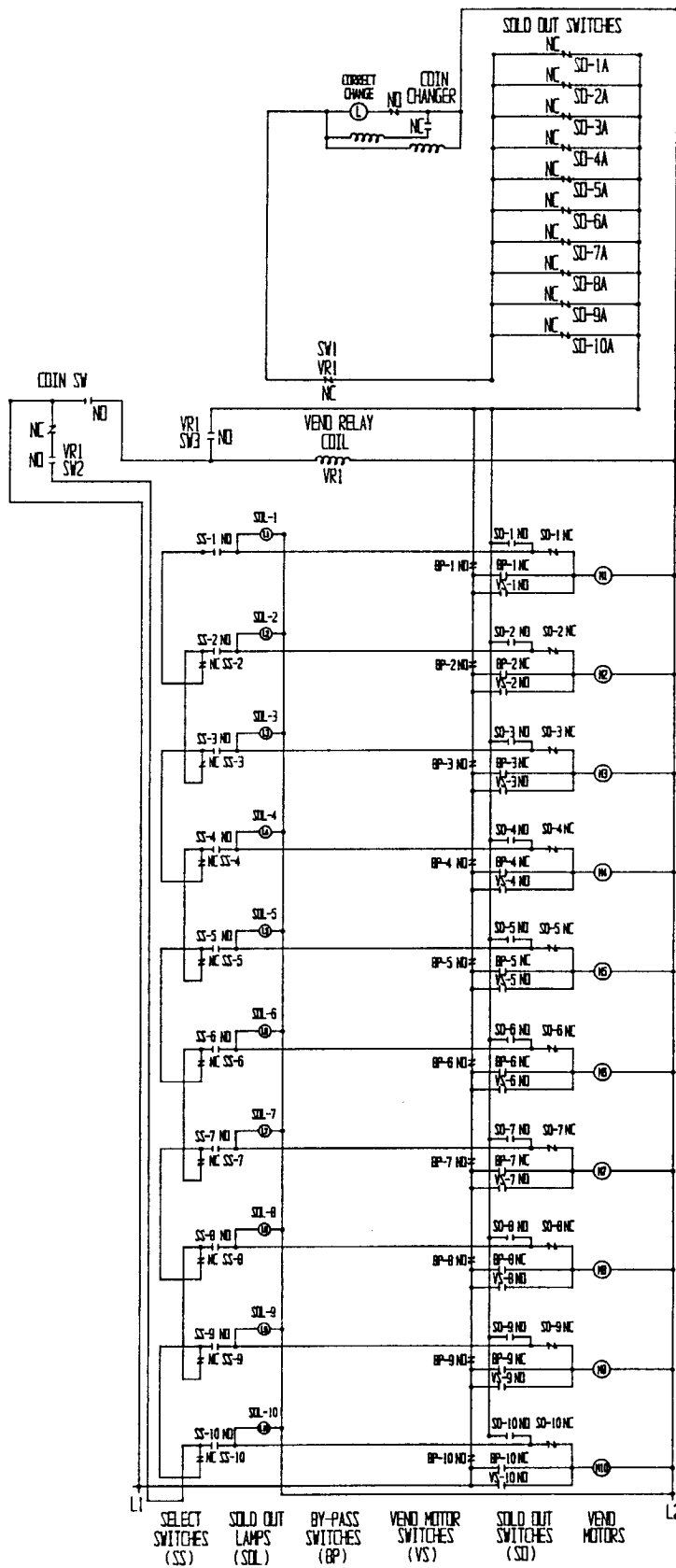

**VEND CYCLE  
SINGLE PRICE**

Refer to across the line wiring diagrams on pages 11, 12, or 13

WHAT DOES IT	WHAT HAPPENS
1. Insert a coin	1. Coin travels into the coin mechanism.
2. The coin	2. Activates the coin vend switch or coin sensor and....
3. The N.O. contact of the coin vend switch or sensor	3. Closes and completes the vend relay coil circuit.
4. The Vend Relay Coil is energized and....	4. The N.O. contact of Vend Relay Switch #3 is closed keeping the vend relay energized.  The N.C. contact of the vend relay switch #1 is opened in the Coin Changer Inhibit circuit.  The N.O. contact of the vend relay switch #2 is closed in the select panel circuit.
5. The coin vend switch or sensor resets and the N.C. contact of the coin vend switch or sensor...	5. Allows power to flow to the select panel and completes the sequence relay coil circuit (some models only).
6. A select button is pushed and the N.O. contact in the select switch...	6. Closes and completes the circuit to the vend motor coil. The Sold Out Light illuminates. The vend motor begins to run.
7. A short time later, the arm of the by-pass switch	7. Drops into the notch of the cam and the N.O. contact of the by-pass switch opens in the select panel circuit.

VEND CYCLE CONTINUED

WHAT DOES IT	WHAT HAPPENS
8. The N.O. contact of the vend relay switch #3	8. Opens in the vend relay coil circuit.
9. The N.O. Contact of the vend relay switch #2	9. Opens in the vend motor coil circuit and opens and breaks the select panel circuit
10. The N.C. contact of the vend relay switch #1	10. Closes in the coin changer circuit and
11. The N.C. contact of the by-pass switch	11. Closes and completes the circuit to the vend motor coil.
12. The vend motor	12. Continues to run
13. The vending cam	13. Works the arm of the vend motor switch and the switch arm rises to the high side of the cam.
14. The N.C. contact of the vend motor switch opens	14. And
15. The N.O. contact of the vend motor switch closes	15. The sold out lamp turns on and The vend motor circuit receives power to keep the motor running.
16. A short time later the arm of the by-pass switch rides to the high side of the cam	16. And
17. The N.O. contact of the by-pass switch closes	17. Enabling the coin changer
18. The vending cam	18. Continues to work the arm of the vend motor switch and the switch arm drops into the notch of the cam
19. The N.O. contact of the vend motor switch opens	19. Breaking the sold out lamp and vend motor coil circuits, the motor stops and the oscillator or rotor stops
20. The N.C. contact of the vend motor switch closes.	20. We are back to stand-by in the vender.

PATENT NOTICE  
 THIS DEVICE IS MANUFACTURED UNDER ONE OR MORE OF THE  
 FOLLOWING U.S. PATENTS.

3,115,276	3,183,266	4,051,400
3,144,866	3,184,622	4,054,622
3,147,841	3,184,886	4,044,877
3,270,817	3,180,837	4,264,000
3,287,536	3,782,164	4,281,138
	4,019,650	4,509,658
	4,509,658	4,782,178

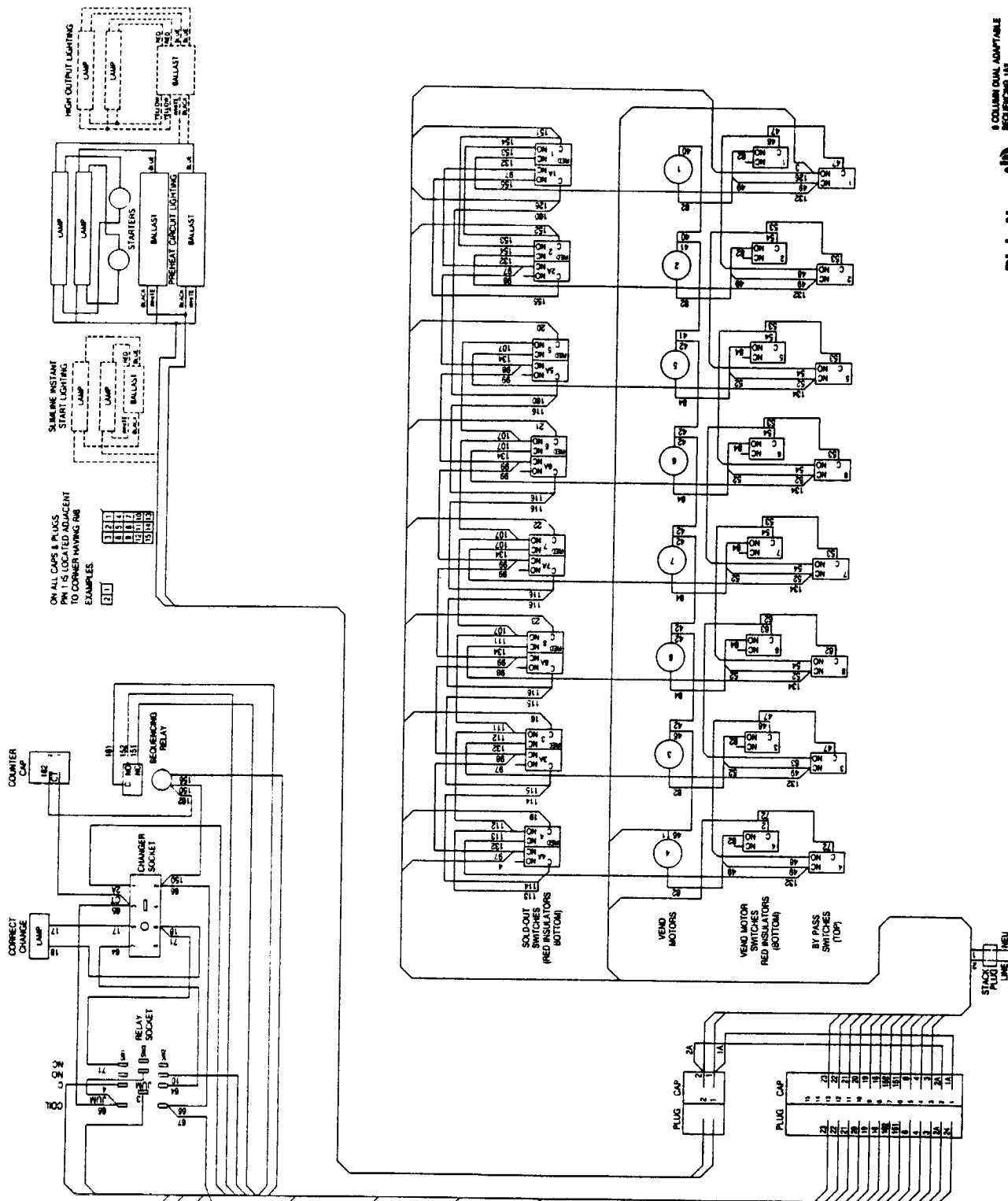

ON ALL COPS & PLUGS  
 SELECTED ADJACENT  
 TO CUSHER TYPING FIG.  
 EXAMPLES:

1	2	3
4	5	6
7	8	9
10	11	12
13	14	15
16	17	18
19	20	21
22	23	24
25	26	27
28	29	30
31	32	33
34	35	36
37	38	39
40	41	42
43	44	45
46	47	48
49	50	51
52	53	54
55	56	57
58	59	60
61	62	63
64	65	66
67	68	69
70	71	72
73	74	75
76	77	78
79	80	81
82	83	84
85	86	87
88	89	90
91	92	93
94	95	96
97	98	99
100	101	102



PA ICE  
 This device is made in accordance with the following U.S. Patents:  
 3,115,274  
 3,141,865  
 3,442,288  
 3,772,517  
 3,267,538  
 4,026,489  
 4,002,671  
 3,442,289  
 3,782,544  
 4,018,650  
 4,358,658  
 4,762,176

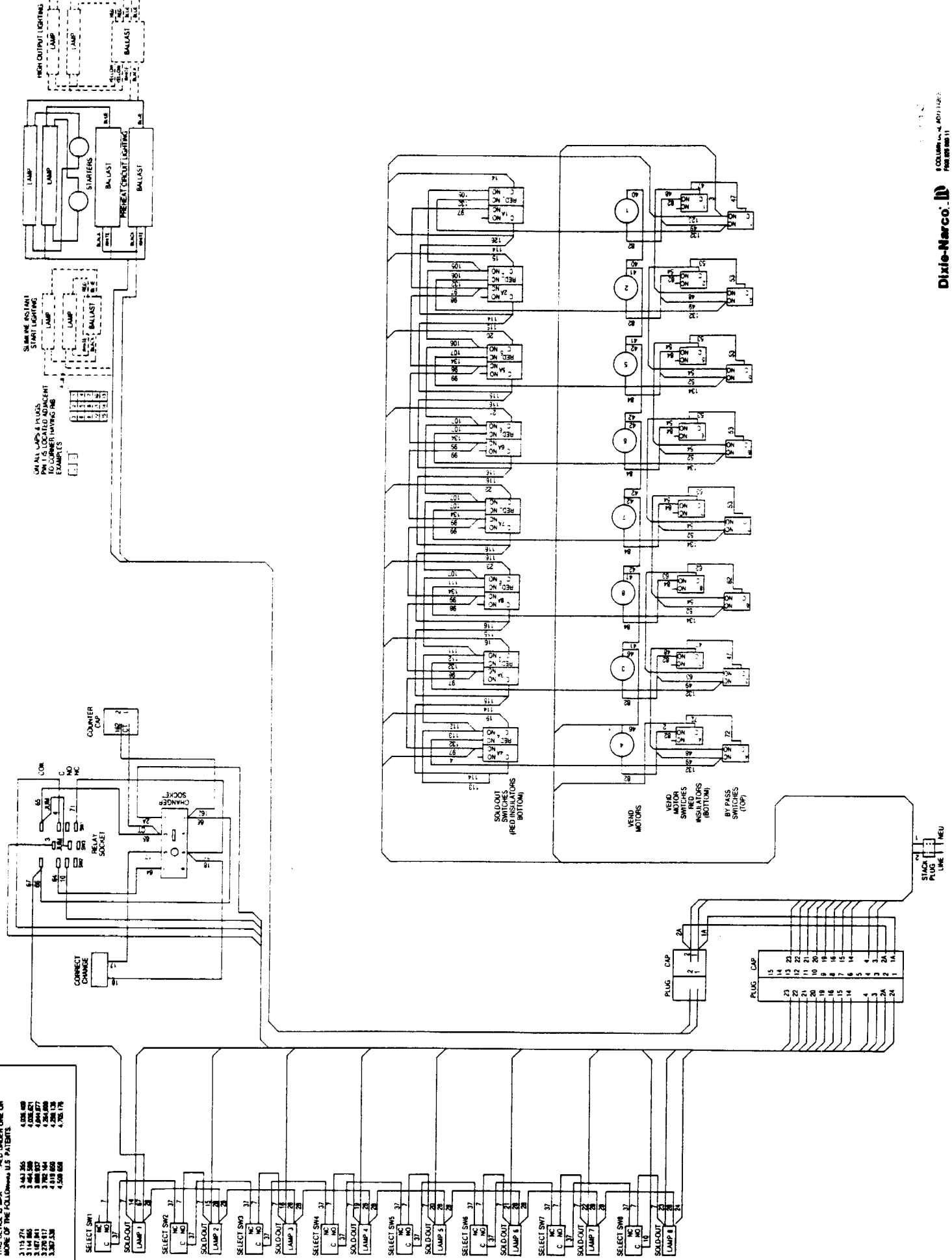

**PATENT NOTICE**

THIS DEVICE IS MANUFACTURED UNDER ONE OR MORE OF THE FOLLOWING U.S. PATENTS.

3,115,274	3,483,365	4,028,400
3,144,965	3,484,538	4,028,621
3,187,841	3,680,937	4,044,877
3,270,817	3,702,164	4,284,000
3,367,536	4,018,650	4,298,138
	4,500,658	4,705,176

